

CUSTOMER TERMINAL	ROHS	Lead (Pb) -free
	YES	YES

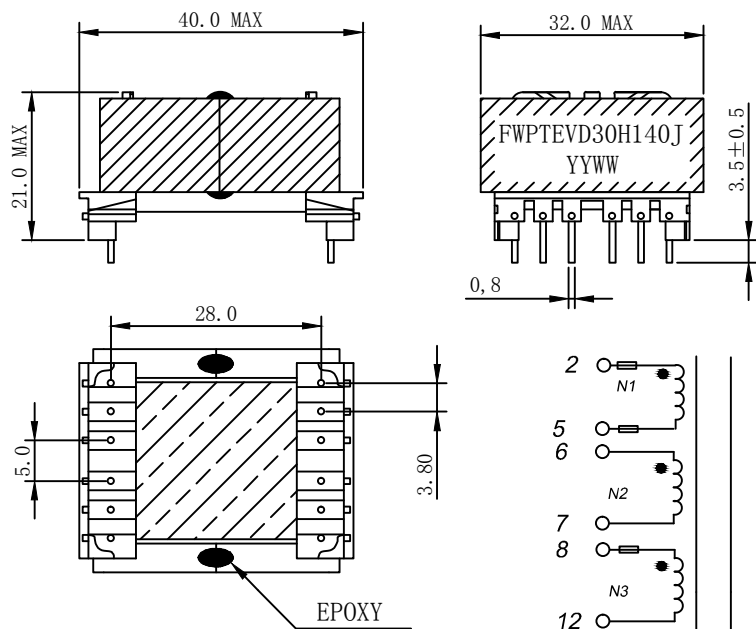

1. Mechanical Dimensions



2. Winding:

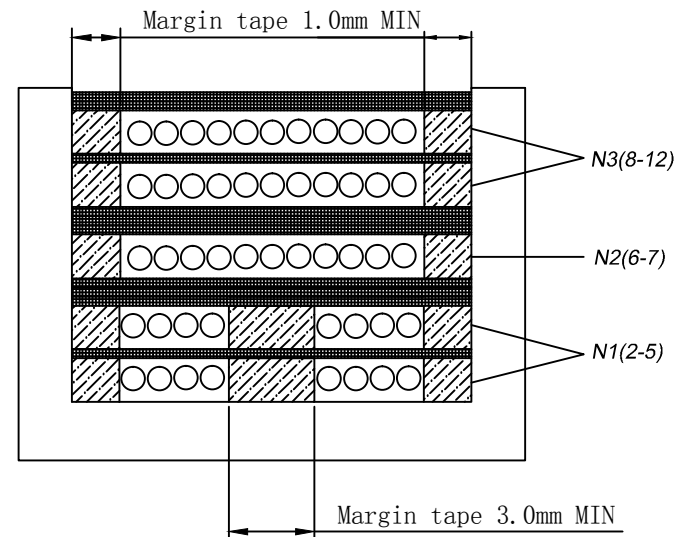

3. Material List

Core:FW40-EVD30

Bobbin:FWB-EVD3001(6+6PIN)

Wire:LITZ

Epoxy:E-500(BLACK)

Margin tape:WF-2902

Sleeving:TFL sleeving

4. Electrical Specification

Inductance: $L(6-7) = 14.7\mu H \pm 3\%$ 10.0KHZ 0.05V

Leakage inductance: $L(6-7) = 500nH$ 10.0KHZ 0.05V
shorted N1,N3

DCR: (6-7)= 38mΩ (2-5)=350mΩ (8-12)=550mΩ

HI-POT: N1-N2 AC 1000V 5mA 2s

N2-N3 AC 1100V 5mA 2s

coil-core AC 2000V 5mA 2s

REV.	DATE	 Convention Placement	DRW.	Drawing Title: TRANSFORMER	Part No:
0	08/13		CHK.		Customer P/N:
RoHS		www.fosopower.com	APP.		Specification Sheet 1 of 1