

## KEY FEATURES

- Switching Power Module for PCB Mountable
- Fully Encapsulated Plastic Case
- Universal Input Range 90-305VAC, 47-440 Hz
- Single and Dual Output
- Regulated Output and Low Ripple and Low Noise
- Isolation Class II
- Maximum No-Load Watts < 0.3W
- Small Size as AHC 5Watt with 8Watt Higher Powe
- CE, UL Approval
- 3-Year Product Warranty



LH08W SERIES



## ELECTRICAL SPECIFICATIONS

All specifications valid at normal input voltage, full load and +25°C after warm-up time unless otherwise stated.

Model No. (Single Output)	FSP008L WVS3V3P	FSP008L WVS3V8P	FSP008L WVS005P	FSP008L WVS008P	FSP008L WVS009P	FSP008L WVS012P	FSP008L WVS014P	FSP008L WVS015P	FSP008L WVS024P											
Max Output Wattage (W)	6.6W	8W	8W	8W	8W	8W	8W	8W	8W											
Input	Voltage										90-305 VAC or 120-430 VDC									
	Frequency (Hz)										47-440 Hz									
	Current (Full load)										180 mA max. (115 VAC) / 110 mA max. (230 VAC)									
	Inrush Current (<500us)										25 A max. (115 VAC) / 45 A max. (230 VAC)									
	Leakage Current										0.25 mA max.									
	External Fuse (recommend)										2 A slow blow type									
Output	Voltage (V.DC.)		3.3V	3.8V	5V	8V	9V	12V	14V	15V	24V									
	Voltage Accuracy		±2%																	
	Current (mA) max		2000	2100	1600	1000	888	666	571	533	335									
	Line Regulation (LL-HL) (typ.)		±0.2%																	
	Load Regulation (balanced)		±1%.					±0.5%.												
	Minimum Load		0%																	
	Maximum Capacitive Load (at 230VAC)		26000uF	25000uF	6000uF	2500uF	2300uF	1050uF	500uF	440uF	180uF									
	Ripple		3.3S~15S : <100mV max (Vp-p)					24S : <150mV max (Vp-p)												
	Noise		3.3S~15S : <150mV max (Vp-p)					24S : <200mV max (Vp-p)												
	Efficiency		69%	71%	72%	79%	79%	79%	80%	80%	81%									
	Hold-up Time		10 ms min.																	
Protection	Over Power Protection		Hiccup technique, auto-recovery																	
	Over Voltage Protection		Zener diode clamp																	
	Short Circuit Protection		Hiccup mode, indefinite (automatic recovery)																	
Isolation	Input-Output (V.AC)		3000V																	
Environment	Operating Temperature		-40°C...+70°C ( with derating )																	
	Storage Temperature		-40°C...+85°C																	
	Temperature Coefficient		±0.02%/°C																	
	Humidity		95% RH																	
	MTBF		>450,000 h @ 25°C (MIL-HDBK-217F)																	
Physical	Dimension (L x W x H)		2.055 x 1.055 x 0.75 Inches ( 52.2 x 26.8 x 19.0 mm ) Tolerance ± 0.5 mm																	
	Case Material		Plastic resin (flammability to UL 94V-0)																	
	Weight		35 g																	
	Cooling Method		Free air convection																	
Safety	Agency Approvals		CE, UL, cUL																	
EMC	EMI (Conducted & Radiated Emission)		EN 55032 class B																	
	EMS (Noise Immunity)		EN 55024																	

## ELECTRICAL SPECIFICATIONS

All specifications valid at normal input voltage, full load and +25°C after warm-up time unless otherwise stated.

Model No. ( Dual Output )	FSP008LUVD005P	FSP008LUVD008P	FSP008LUVD012P	FSP008LUVD7V5P		
Max Output Wattage (W)	9W	8.75W	9W	8.6W		
Input	Voltage					
	90-305 VAC or 120-430 VDC					
	Frequency (Hz)					
	47-440 Hz					
	Current (Full load)					
	200 mA max. (115 VAC) / 125 mA max. (230 VAC)					
Input	Inrush Current (<500us)					
	25 A max. (115 VAC) / 45 A max. (230 VAC)					
	Leakage Current					
	0.25 mA max.					
	External Fuse (recommnd)					
	2 A slow blow type					
Output	Voltage (V.DC.)		Vo : 5V Vr : 3.3V	Vo : 8V Vr : 5V	Vo : 12V Vr : 5V	Vo : 12V Vr : 7.5V
	Voltage Accuracy		Vo : ±2% Vr : ±15%	Vo : ±2% Vr : ±5%		
	Current (mA) max		1600 / 310	1000 / 150	666 / 200	560 / 250
	Line Regulation (LL-HL) (typ.)		Vo : ±0.2% Vr : ±3%			
	Load Regulation (balanced)		Vo : ±0.5% Vr : ±5%			
	Minimum Load		25%			
	Maximum Capacitive Load (at 230VAC)		Vo : 1200uF Vr : 1000uF	Vo : 800uF Vr : 3800uF	Vo : 260 uF Vr : 3800uF	Vo : 260 uF Vr : 4000uF
	Ripple		<100mV max (Vp-p)			
	Noise		<150mV max (Vp-p)			
	Efficiency		71%	77%	78%	78%
	Hold-up Time		10 ms min.			
Protection	Over Power Protection		Hiccup technique, auto-recovery			
	Over Voltage Protection		Zener diode clamp			
	Short Circuit Protection		Hiccup mode, indefinite (automatic recovery)			
Isolation	Input-Output (V.AC)		3000V			
Environment	Operating Temperature		-40°C...+70°C ( with derating )			
	Storage Temperature		-40°C...+85°C			
	Temperature Coefficient		±0.02%/°C			
	Humidity		95% RH			
	MTBF		>450,000 h @ 25°C (MIL-HDBK-217F)			
Physical	Dimension (L x W x H)		2.055 x 1.055 x 0.75 Inches ( 52.2 x 26.8 x 19.0 mm ) Tolerance ±0.5 mm			
	Case Material		Plastic resin (flammability to UL 94V-0)			
	Weight		35 g			
	Cooling Method		Free air convection			
Safety	Agency Approvals		CE, UL, cUL			
EMC	EMI (Conducted & Radiated Emission)		EN 55032 class B			
	EMS (Noise Immunity)		EN 55024			

### NOTE

- Ripple & Noise are measured at 20MHz of bandwidth with 0.1uF & 47uF parallel capacitor.
- Cross Regulation for dual output:
  - If  $I_o=100\% \sim 80\%$  &  $I_r=100\% \sim 80\%$  then Corss Regulation  $\leq \pm 10\%$
  - If  $I_o=100\% \sim 25\%$  &  $I_r=100\% \sim 25\%$  then Corss Regulation  $\leq \pm 18\%$
- It's necessary Varistor 14S561K at L / N input side in parallel.
- It's necessary 10R / 15φ thermistor at L input side in series connection.

### OUTPUT NOISE

The output noise is measured with 47  $\mu$  F tantalum capacitor and 0.1  $\mu$  F ceramic capacitor across output.

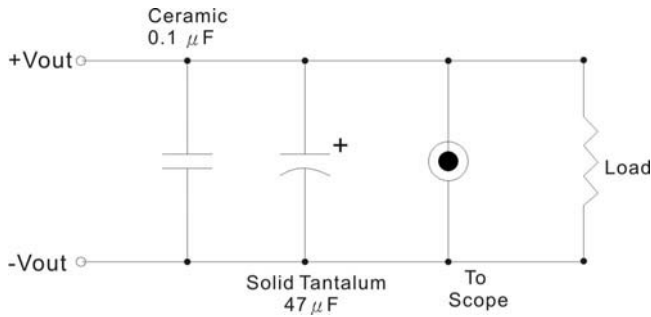

### MECHANICAL DIMENSION ( Top View )

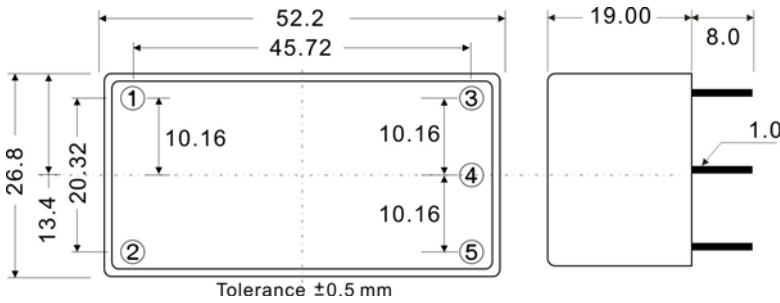

PIN#	Single	Dual
1	AC IN (N)	AC IN (N)
2	AC IN (L)	AC IN (L)
3	+DC OUT	+DC OUT
4	-DC OUT	-DC OUT
5	NO PIN	VR

### BLOCK DIAGRAM

Single Output

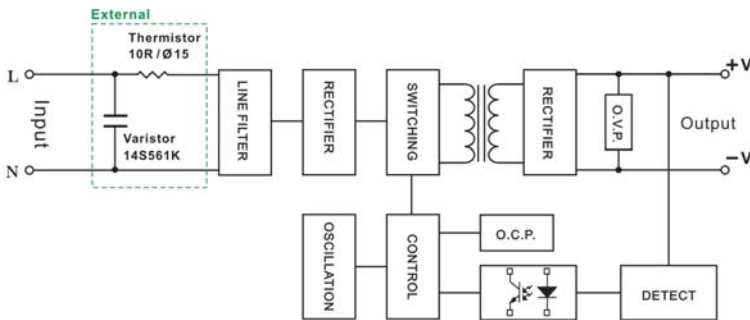

Dual Output

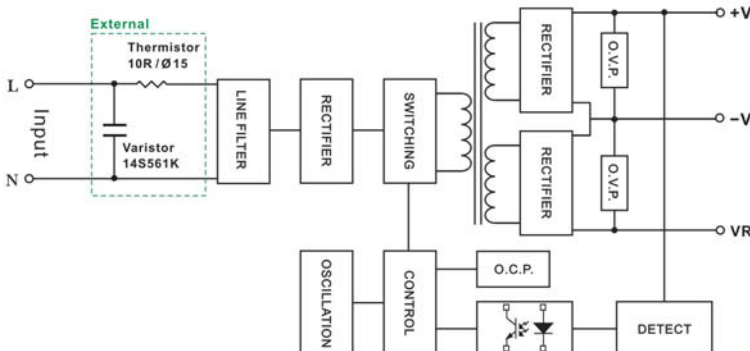

### DERATING

