

KEY FEATURES

- Switching Power Module for PCB Mountable
- Fully Encapsulated Plastic Case
- Universal Input Range 90-264 VAC, 47-63 Hz
- Low Ripple and Noise
- Isolation Class II
- Maximum No-Load Watts < 0.3W
- CE , UL Approval
- 3-Year Product Warranty

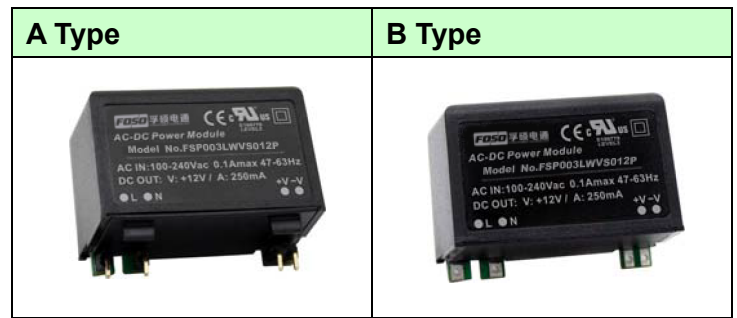

LI03W SERIES



ELECTRICAL SPECIFICATIONS

All specifications valid at normal input voltage, full load and +25°C after warm-up time unless otherwise stated.

Model No.	FSP003LWVS3V3P	FSP003LWVS005P	FSP003LWVS009P	FSP003LWVS012P	FSP003LWVS015P	FSP003LWVS024P						
Max Output Wattage (W)	2.97W	3W	3W	3W	3W	3W						
Input	Voltage						90-264 VAC or 120-370 VDC					
	Frequency (Hz)						47-63 Hz					
	Current (Full load)						75 mA max. (115 VAC) / 55 mA max. (230 VAC)					
	Inrush Current (<500us)						20 A max. (115 VAC) / 50 A max. (230 VAC)					
	Leakage Current						0.25 mA max.					
	External Fuse (recommend)						3.15 A slow blow type					
Output	Voltage (V.DC.)		3.3V	5V	9V	12V	15V	24V				
	Voltage Accuracy						±10%					
	Current (mA) max						900	600	333	250	200	125
	Line Regulation (LL-HL) (typ.)						±5%	±2%				
	Load Regulation (0-100%) (typ.)						±5%	±2%				
	Minimum Load						0%					
	Maximum Capacitive Load (at 230VAC)		14000uF	8000uF	3200uF	1500uF	1000uF	470uF				
	Ripple & Noise (Vp-p) max						<250mV	<200mV	<150mV	<100mV		
	Efficiency						69%	71%	76%	76%	76%	77%
Hold-up Time						15 ms min.						
Protection	Over Power Protection						Hiccup technique, auto-recovery					
	Over Voltage Protection						Zener diode clamp					
	Short Circuit Protection						Hiccup mode, indefinite (automatic recovery)					
Isolation	Input-Output (V.AC)						3750V					
Environment	Operating Temperature						-40°C...+85°C (with derating)					
	Storage Temperature						-40°C...+85°C					
	Temperature Coefficient						±0.02%/°C					
	Humidity						95% RH					
	MTBF						>650,000 h @ 25°C (MIL-HDBK-217F)					
Physical	Dimension (L x W x H)						1.41x 0.75 x 0.86 Inches (35.7 x 19.0 x 22.0 mm) Tolerance±0.5 mm					
	Case Material						Plastic resin (flammability to UL 94V-0)					
	Weight						26 g					
	Cooling Method						Free air convection					
Safety	Agency Approvals						UL, cUL, CE					
EMC	EMI (Conducted & Radiated Emission)						EN 55032 class B					
	EMS (Noise Immunity)						EN 55024					

NOTE

1. Ripple & Noise are measured at 20MHz of bandwidth with 0.1uF & 47uF parallel capacitor.
2. It's necessary Varistor 14S471K at L / N input side in parallel.
3. It's necessary 10R / 15 ϕ thermistor at L input side in series connection.

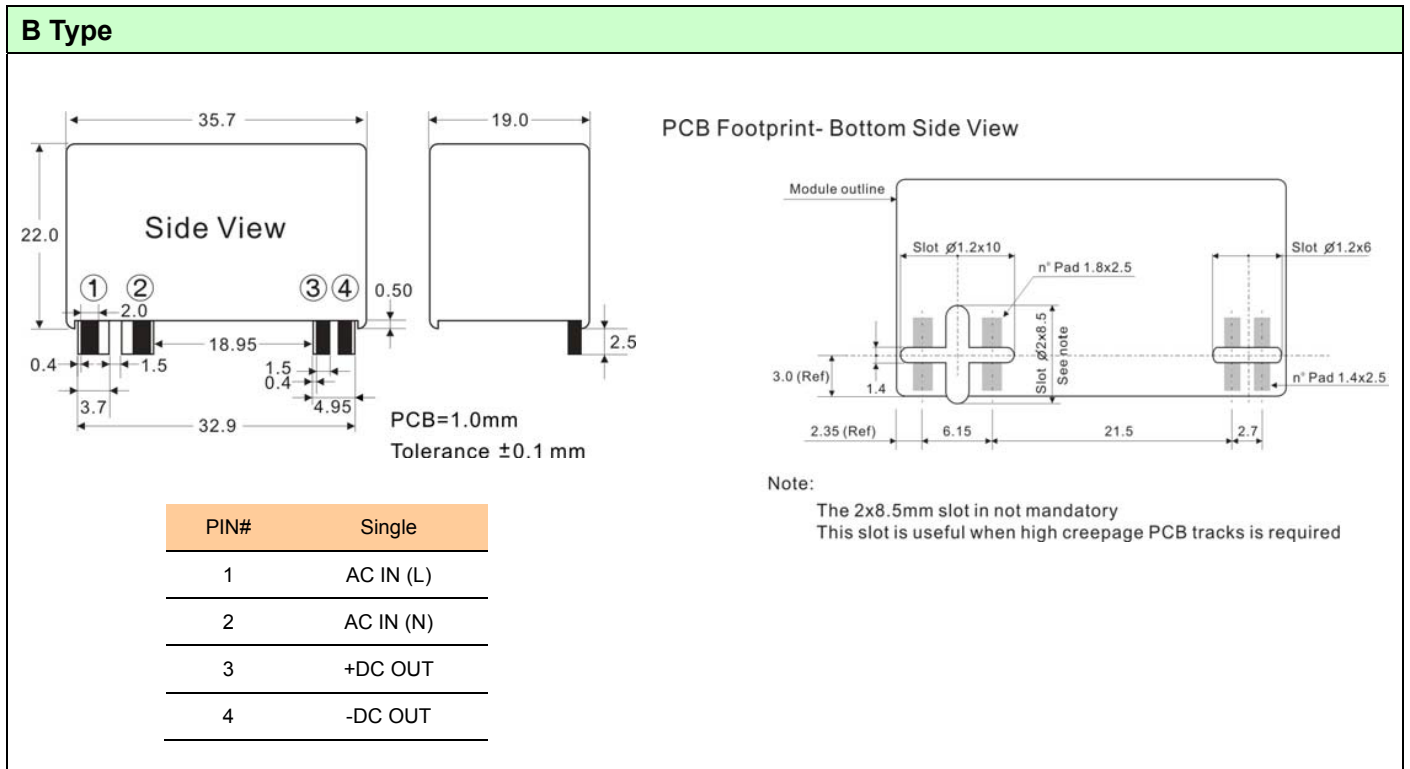
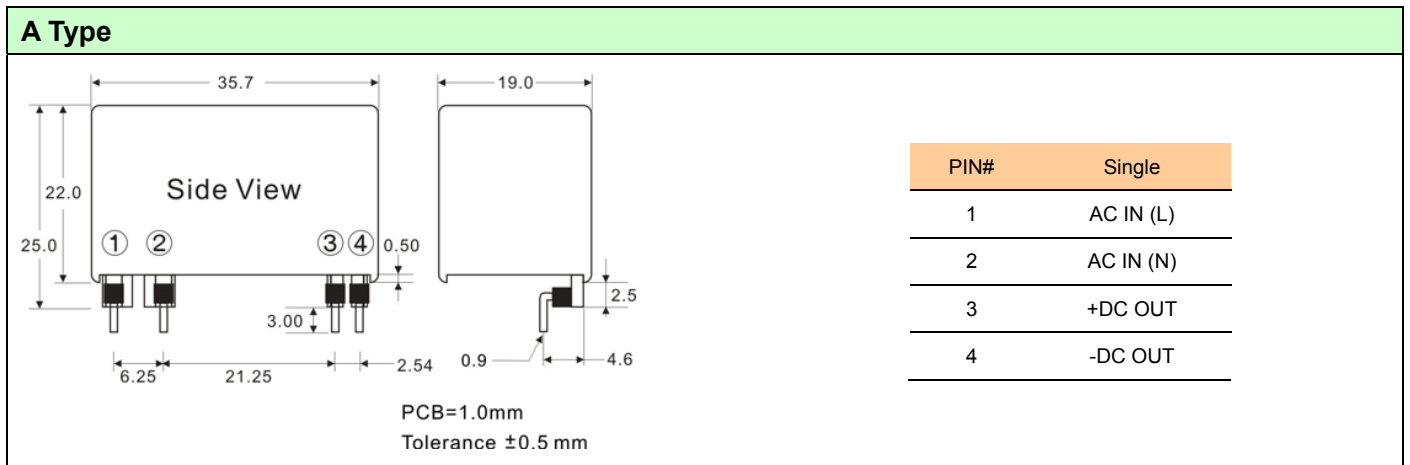
MECHANICAL DIMENSION

BLOCK DIAGRAM

Single Output

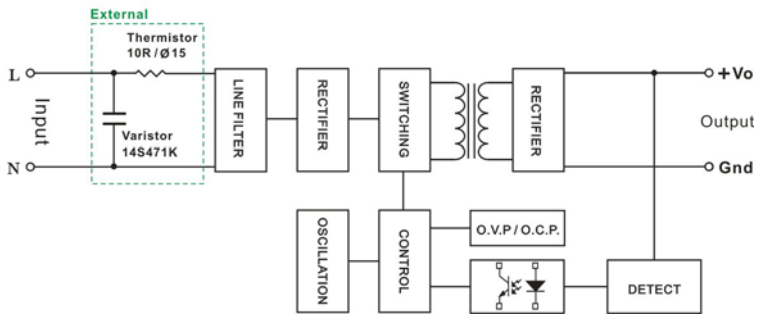

DERATING

