

KEY FEATURES

- Switching Power Module for PCB Mountable
- Fully Encapsulated Plastic Case
- Universal Input Range 90-305VAC, 47-63 Hz
- Isolation Class II
- Maximum No-Load Watts < 0.3W
- CE, CB and UL Approval
- 3-Year Product Warranty



LZ02W SERIES



ELECTRICAL SPECIFICATIONS

All specifications valid at normal input voltage, full load and +25°C after warm-up time unless otherwise stated.

Model No. (Single Output)	FSP002LUVS3V3P	FSP002LUVS005P	FSP002LUVS009P	FSP002LUVS012P	FSP002LUVS015P	FSP002LWVS024P	
Max Output Wattage (W)	2W						
Input	Voltage	90-305 VAC or 120-430 VDC					
	Frequency (Hz)	47-63 Hz					
	Current (Full load)	75 mA max. (115 VAC) / 55 mA max. (230 VAC)					
	Inrush Current (<2ms)	30 A max. (115 VAC) / 50 A max. (230 VAC)					
	Leakage Current (<240 VAC)	0.25 mA max.					
	External Fuse (mandatory)	3.15 A slow blow type					
	External Varistor	14S561K					
Output	Voltage (V.DC.)	3.3V	5V	9V	12V	15V	24V
	Voltage Accuracy	±6%					
	Current (mA) max	600	400	222	167	133	83
	Line Regulation (LL-HL) (typ.)	±5%					
	Load Regulation (10-100%) (typ.)	±6%					
	Minimum Load	0%					
	Maximum Capacitive Load	7000uF	4000uF	1200uF	500uF	350uF	110uF
	Ripple & Noise (Vp-p)	300mV					
	Efficiency (at 115 VAC)	66%	70%	73%	73%	73%	75%
Hold-up Time (at 230 VAC)	15 ms min.						
Protection	Over Power Protection	Hiccup technique, auto-recovery					
	Short Circuit Protection	Hiccup mode, indefinite (automatic recovery)					
Isolation	Input-Output (V.AC)	3000V					
Environment	Operating Temperature	-40°C...+80°C (with derating)					
	Storage Temperature	-40°C...+85°C					
	Temperature Coefficient	±0.02%/°C					
	Humidity	95% RH					
	MTBF	>450,000 h @ 25°C (MIL-HDBK-217F)					
Physical	Dimension (L x W x H)	1.13 x 1.03 x 0.68 Inches (28.8 x 26.1 x 17.3 mm) Tolerance ± 0.5 mm					
	Case Material	Plastic resin (flammability to UL 94V-0)					
	Weight	19.9 g					
	Cooling Method	Free air convection					
Safety	Agency Approvals	UL, cUL, CE, CB					
EMC	EMI (Conducted & Radiated Emission)	EN 55032 class B					
	EMS (Noise Immunity)	EN 55024					

NOTE

1. Ripple & Noise are measured at 20MHz of bandwidth with 0.1uF & 47uF parallel capacitor.
2. Hold-up Time measured at 90% Vout.
3. It's necessary Varistor 14S561K at L / N input side in parallel.
4. It's necessary 10R / 15 ϕ thermistor at L input side in series connection.

MECHANICAL DIMENSION (Top View)

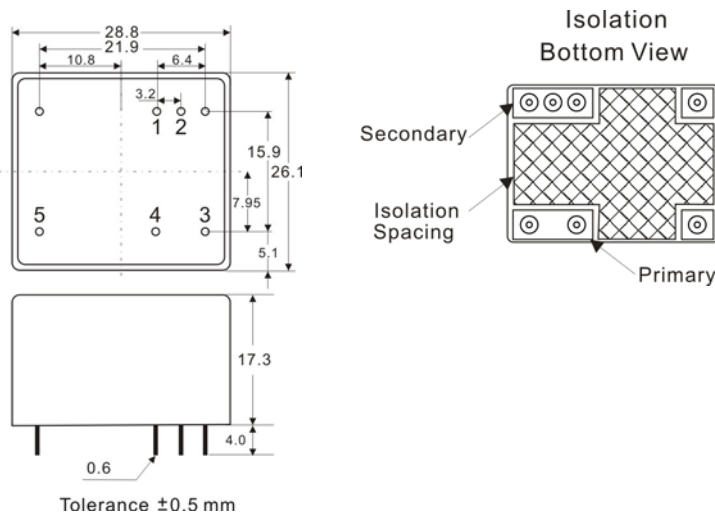

PIN#	Single
1	+DC OUT
2	-DC OUT
3	AC IN (N)
4	AC IN (L)
5	NC

BLOCK DIAGRAM

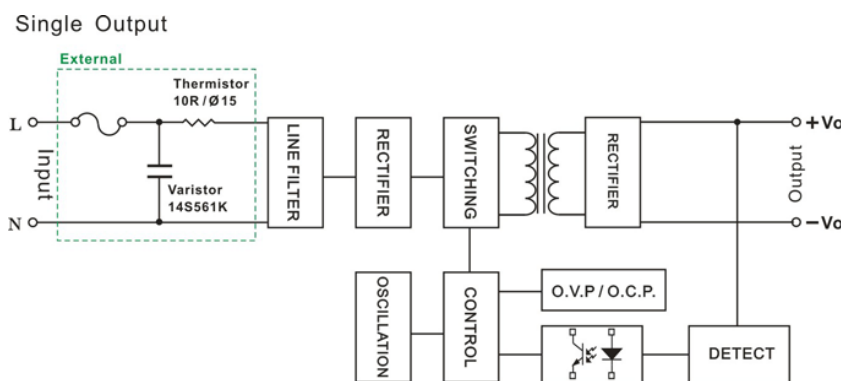

DERATING

